

Wall Mount Cabinets, Racks & Accessories



Wall Mount - Dual Hinge

Wall Mount Cabinets & Frames

Cooper B-Line offers the innovative wall mount products with designs and features to fit most applications. All B-Line wall mount products conform to EIA 310-D universal hole spacing and are manufactured from high quality steel or aluminum. Whether in the classroom, telecommunication closet, network centers or warehouse, B-Line is the first choice for wall mounted cabinets and frames that will provide solid support and required flexibility for present and future technology.

Features

- High quality 16 ga. (1.5mm) steel construction
- Heavy duty, field reversible, hinge and lock system
- 300 lbs. (136kg) equipment capacity
- Mounting holes 16" (406mm) on centers for easy mounting to 16" (406mm) stud spacing
- Fully adjustable EIA-310-D front mounting rail system with #12-24 tapped holes
- Top and bottom cable/conduit knockouts
- Power strips and cable management can be mounted on back panel or optional mounting rails
- Grilled bottom with filter option for increased air flow
- Powder coat finish in three standard colors shown above, (other colors available upon request)
- Other accessories available (see pages 12-15)

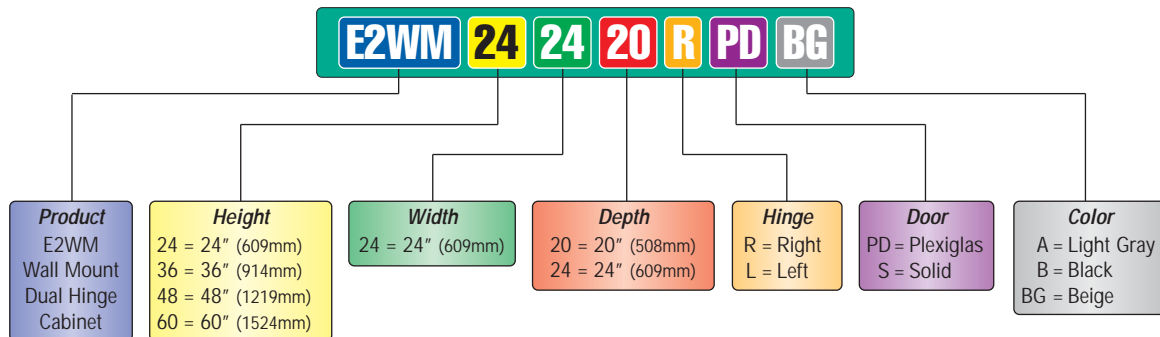

Cabinet Number*	Usable EIA Mtg U's	Height 'H'		Width 'W'		Depth 'D'		'A'		Load Capacity		Approx. Weight			
		in.	(mm)	in.	(mm)	in.	(mm)	in.	(mm)	lbs.	(kg)	Plexiglas		Solid	
E2WM242420	11	24.00	610	24.09	612	20.00	508	13.96	355	300	136	68.8	31.2	69.4	31.5
E2WM242424						24.00	610	17.96	456	300	136	76.3	34.6	76.9	34.9
E2WM362420	18	36.25	921	24.09	612	20.00	508	13.96	355	300	136	88.0	39.9	89.2	40.5
E2WM362424						24.00	610	17.96	456	300	136	96.9	44.0	98.1	44.5
E2WM482420	25	48.50	1232	24.09	612	20.00	508	13.96	355	300	136	117.5	53.3	109.0	49.4
E2WM482424						24.00	610	17.96	456	300	136	117.5	53.3	119.4	54.1
E2WM602420	32	60.75	1543	24.09	612	20.00	508	13.96	355	300	136	129.5	58.7	132.0	59.9
E2WM602424						24.00	610	17.96	456	300	136	142.1	64.4	144.6	65.6

_ Add Hinge, Door & Color Code suffix to complete part number.

Dual Hinge Accessories

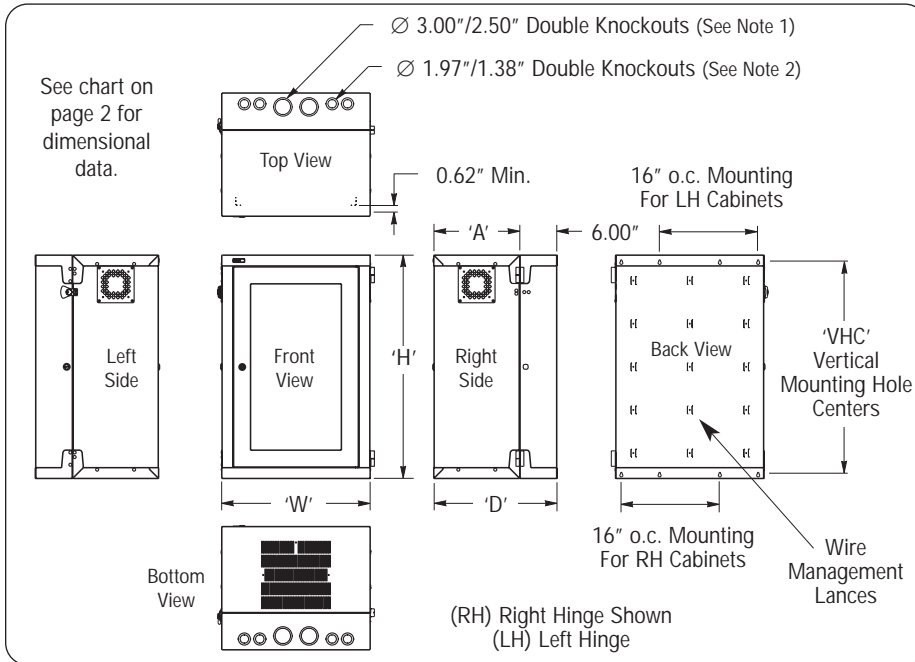

Note 1 - For 3" bushing or 2" conduit connector

Note 2 - For 1" or 1 1/2" conduit connector

Usable EIA Mtg U's	'VHC'	
	in.	(mm)
11	22 ³ / ₄	578
18	35	889
25	47 ¹ / ₄	1200
32	59 ¹ / ₂	1511

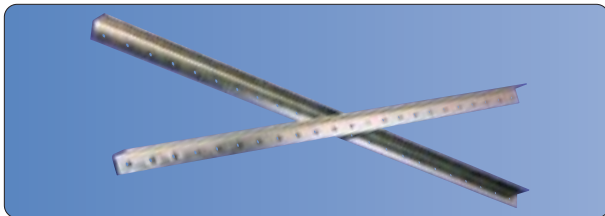

Additional Front Section Mounting Rails

Catalog Number	Rack Mtg. Units	Fits Cabinet Height
E2WMMR1324	13	24"
E2WMMR2024	20	36"
E2WMMR2724	27	48"
E2WMMR3424	34	60"

Includes (1) one pair of #12-24 tapped mounting rails, EIA 310-D spacing, and assembly hardware.

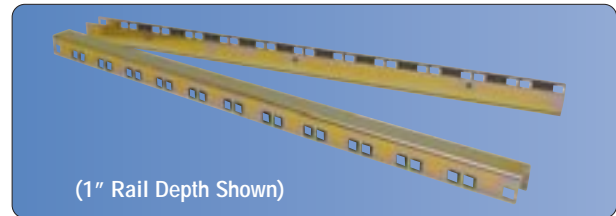

Rear Section Mounting Rails

Catalog Number	Rack Mtg. Units	Rail Depth	Fits Cabinet Height
E2WMMCK10012	12	1.00"	24" or larger
E2WMMCK10016	16	1.00"	36" or larger
E2WMMCK10020	20	1.00"	36" or larger
E2WMMCK10024	24	1.00"	48" or larger
E2WMMCK35012	12	3.50" *	24" or larger
E2WMMCK35016	16	3.50" *	36" or larger
E2WMMCK35020	20	3.50" *	36" or larger
E2WMMCK35024	24	3.50" *	48" or larger

Includes (1) one pair of mounting rails, (20) #12-24 cage nuts and pan head machine screws, and assembly hardware.

* Includes holes to accommodate 3" bushing kit shown below.



Fan Kit - E2-FA-2H-210-AC
210cfm 48dBa, 110 volt, 60 cycle

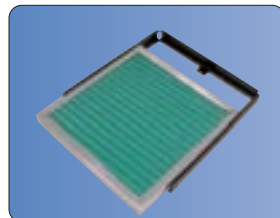

Filter Kit - E2WMFK
Heavy duty washable filter
.04" wc initial resistance



3" Bushing Kit - E018757
Used for 3" knockout to decrease wire chafing

TF Wall Boxes

TF Wall Boxes are designed are great for small offices, home network and audio visual centers. Utilizing unique patented frame and removable hinged doors and side panels enables TF Wall Boxes to provide improved access and wire maintenance.

Standard TF Wall Boxes are available as fixed or swing frame styles.

Standard Sizes: Height - 12U = 26" (660mm), 15U = 31¹/₄" (794mm), and 21U = 41³/₄" (1048mm)

Widths - 25³/₁₆" (640mm)

Depths - 13³/₄" (350mm) and 19¹/₁₆" (500mm)

DISCONTINUED

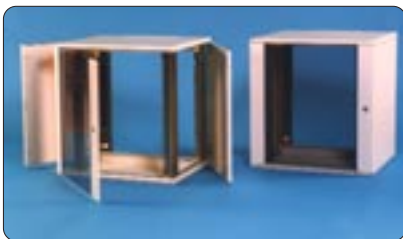

Fixed Frame

Fixed Frame

TF Fixed Frame Wall Boxes are supplied fully assembled with the following items:

- Frame
- Top and bottom panels
- 2 hinged and removable side panels - plain or vented
- Reversible glass front door hinged left or right, removable and lockable
- 2 cable strain relief brackets, top/bottom rear
- 19" EIA square hole mounting rails (front/rear adjustable)



Swing Frame

Swing Frame

TF Swing Frame Wall Boxes are designed for networking, cabling/patching and other applications where maximum rear equipment access is needed.

Swing frame provides a 225° opening and can pivot (hinge) left or right.

Supplied fully assembled with the following items:

- Frame
- Top and bottom panels
- 2 hinged and removable side panels - plain or vented
- Reversible glass front door hinged left or right, removable and lockable
- 2 cable strain relief brackets, top/bottom rear
- Swing frame with 19" EIA square hole mounting rails

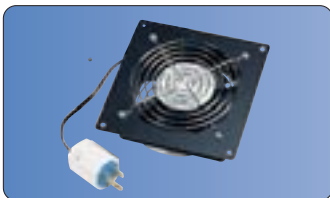

Fan Kit - AFA105AC

105cfm 43.4dBA, 110 volt, 60 cycle
Designed for use with vented side panels.

Note: Fan is optional. When required, only one (1) fan per cabinet is needed. Fan can be mounted on right or left side of cabinet.

Optional items

- Screws and cage nuts must be ordered separately (see sizes page 14)
- Fans Kits (see this page)
- Other accessories (see pages 12-15)

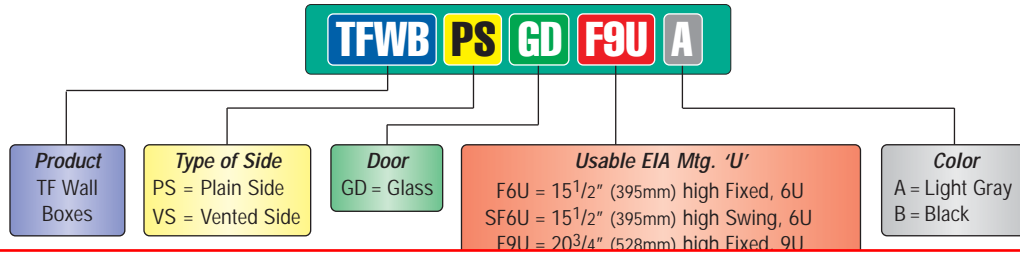

DISCONTINUED

Unit Height	Mounting Hole Centers			
	Horizontal 'HC'		Vertical 'VC'	
	in.	(mm)	in.	(mm)
12U	22 ¹ / ₄	565	16 ¹ / ₂	420
15U	22 ¹ / ₄	565	21 ³ / ₄	553
21U	22 ¹ / ₄	565	32 ¹ / ₄	820

Fixed Frame - 19" EIA Part Number*		Swing Frame - 19" EIA Part Number*		Usable EIA Mtg. U's	Depth 'D'		Overall Height 'H'	
Non-Vented	Vented	Non-Vented	Vented		in.	(mm)	in.	(mm)
TFWBPSGDF12U	TFWBVSGDF12U	TFWBPSGDSF12U	TFWBVSGDSF12U	12	19 ¹¹ / ₁₆	500	26	661
TFWBPSGDF15U	TFWBVSGDF15U	TFWBPSGDSF15U	TFWBVSGDSF15U	15	19 ¹¹ / ₁₆	500	31 ¹ / ₄	795
TFWBPSGDF21U	TFWBVSGDF21U	TFWBPSGDSF21U	TFWBVSGDSF21U	21	19 ¹¹ / ₁₆	500	41 ³ / ₄	1061

* Add Color Code suffix to complete part number.

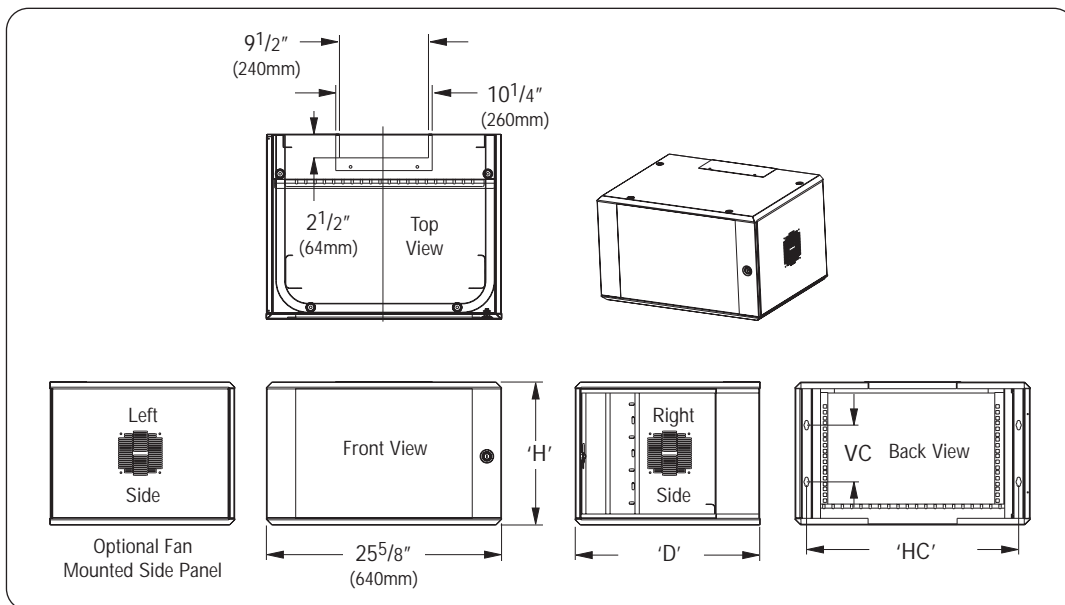

Dynamic Dual Relay Rack

The B-Line Dual Relay Rack provides the functionality and versatility needed in telecom closets where space and accessibility are at a premium or when equipment allows minimal space for rear connectivity. This patented design features either right or left hinge function by simply pushing the red top and bottom slide locks to the right or left.

Features

- Front frame hinges on either side providing convenient access to back of equipment
- Modular design permits easy installation by one person
- Design eliminates corner gussets, maximizing usable depth for all mounting units
- Wall mounting slots on 16" (406mm) centers
- Multiple racks can be installed side by side or vertically
- Front frame can be completely removed from rack after installation
- Universal ($\frac{5}{8}$ " (16mm), $\frac{5}{8}$ " (16mm), $\frac{1}{2}$ " (13mm)) mounting hole spacing
- Can be locked for added security
- Available in EIA widths 19" (482mm) and 23" (584mm)
- Available in heights of 6U = 16" (406mm), 11U = 24" (609mm), 19U = 38" (965mm) and 25U = 49" (1244mm)
- Available in depths of 5" (127mm), 8" (203mm), 12" (305mm) and 18" (457mm)
- Load Rating: 100 Lbs. (45kg)
- Material: Steel



Hinging from left side



Hinging from right side

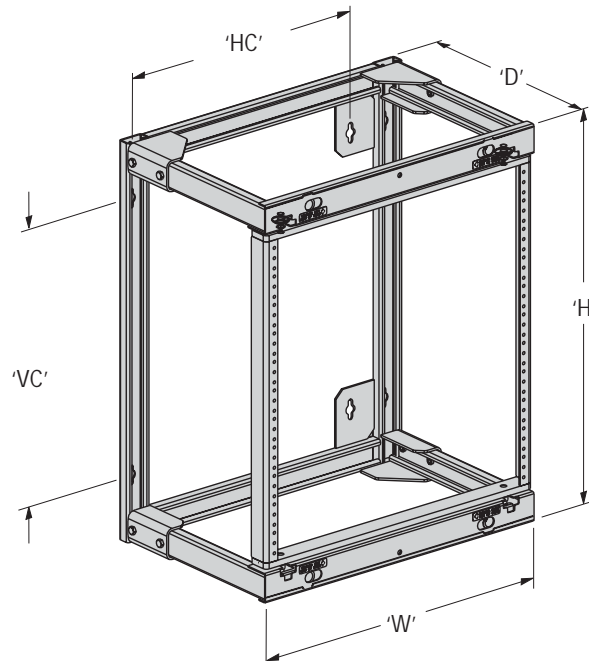

Unit Height U's	Mounting Hole Centers			
	Horizontal 'HC'		Vertical 'VC'	
	in.	(mm)	in.	(mm)
6	16	406	8 ¹ / ₄	420
11	16	406	17	553
19	16	406	31	820
25	16	406	41 ¹ / ₂	820

Dynamic Dual Relay Rack

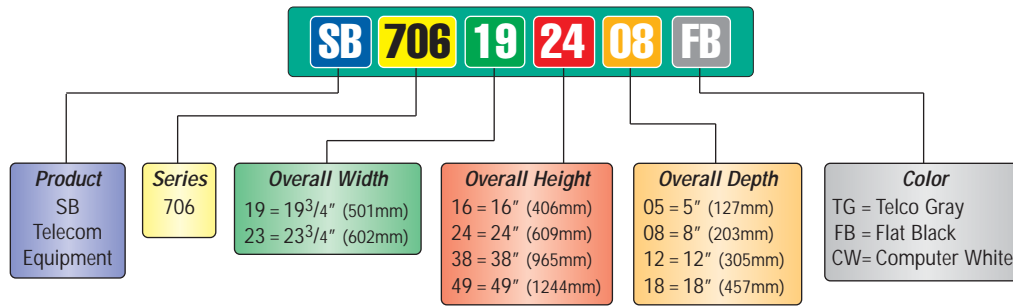

Part Number*	Rack Width		'W' Overall Width		Usable EIA Mounting U's	'H' Overall Height		'D' Overall Depth		Weight	
	in.	(mm)	in.	(mm)		in.	(mm)	in.	(mm)	lbs.	(kg)
SB706191605	19"	482	19.73"	501	6	16"	406	5"	127	24.9	11.3
SB706191608	19"	482	19.73"	501	6	16"	406	8"	203	26.8	12.1
SB706191612	19"	482	19.73"	501	6	16"	406	12"	305	28.5	12.9
SB706191618	19"	482	19.73"	501	6	16"	406	18"	457	31.1	14.1
SB706192405	19"	482	19.73"	501	11	24"	609	5"	127	27.9	12.6
SB706192408	19"	482	19.73"	501	11	24"	609	8"	203	29.8	13.5
SB706192412	19"	482	19.73"	501	11	24"	609	12"	305	31.5	14.3
SB706192418	19"	482	19.73"	501	11	24"	609	18"	457	34.1	15.4
SB706193805	19"	482	19.73"	501	19	38"	965	5"	127	32.7	14.8
SB706193808	19"	482	19.73"	501	19	38"	965	8"	203	34.6	15.7
SB706193812	19"	482	19.73"	501	19	38"	965	12"	305	36.3	16.4
SB706193818	19"	482	19.73"	501	19	38"	965	18"	457	38.9	17.6
SB706194905	19"	482	19.73"	501	25	49"	1244	5"	127	36.3	16.4
SB706194908	19"	482	19.73"	501	25	49"	1244	8"	203	38.3	17.4
SB706194912	19"	482	19.73"	501	25	49"	1244	12"	305	39.9	18.1
SB706194918	19"	482	19.73"	501	25	49"	1244	18"	457	42.4	19.2
SB706231605	23"	584	23.73"	602	6	16"	406	5"	127	29.0	13.1
SB706231608	23"	584	23.73"	602	6	16"	406	8"	203	30.9	14.0
SB706231612	23"	584	23.73"	602	6	16"	406	12"	305	32.6	14.8
SB706231618	23"	584	23.73"	602	6	16"	406	18"	457	35.0	15.9
SB706232405	23"	584	23.73"	602	11	24"	609	5"	127	32.0	14.5
SB706232408	23"	584	23.73"	602	11	24"	609	8"	203	33.9	15.4
SB706232412	23"	584	23.73"	602	11	24"	609	12"	305	35.6	16.1
SB706232418	23"	584	23.73"	602	11	24"	609	18"	457	38.1	17.3
SB706233805	23"	584	23.73"	602	19	38"	965	5"	127	36.8	16.7
SB706233808	23"	584	23.73"	602	19	38"	965	8"	203	38.7	17.5
SB706233812	23"	584	23.73"	602	19	38"	965	12"	305	40.4	18.3
SB706233818	23"	584	23.73"	602	19	38"	965	18"	457	42.9	19.4
SB706234905	23"	584	23.73"	602	25	49"	1244	5"	127	40.4	18.3
SB706234908	23"	584	23.73"	602	25	49"	1244	8"	203	42.3	19.2
SB706234912	23"	584	23.73"	602	25	49"	1244	12"	305	44.0	19.9
SB706234918	23"	584	23.73"	602	25	49"	1244	18"	457	46.5	21.1

* Add Color Code suffix to complete part number.

Wall Mount Relay Rack

The Wall Mount Relay Rack offers a economical solution for rack mounted equipment and patch panel installations where equipment and components do not require security.

Features

- 19" or 23" EIA-310-D mounting rail system with #12-24 tapped holes
- Double sided universal ($\frac{5}{8}$ " (16mm), $\frac{5}{8}$ " (16mm), $\frac{1}{2}$ " (13mm)) mounting hole spacing
- 19" (482mm) and 23" (584mm) widths
- 14U = 25" (635mm), 22U = 39" (991mm) and 42U = 72" (1829mm) heights
- 100 lb. (45kg) load capacity
- 6" (152mm), 12" (305mm) and 18" (457mm) depths
- Material: 6061-T6 aluminum alloy
- Finish: Brushed Aluminum (BRSH)
Telco Gray Powder Coat (TG)
Flat Black Powder Coat (FB) or
Computer White Powder Coat (CW)

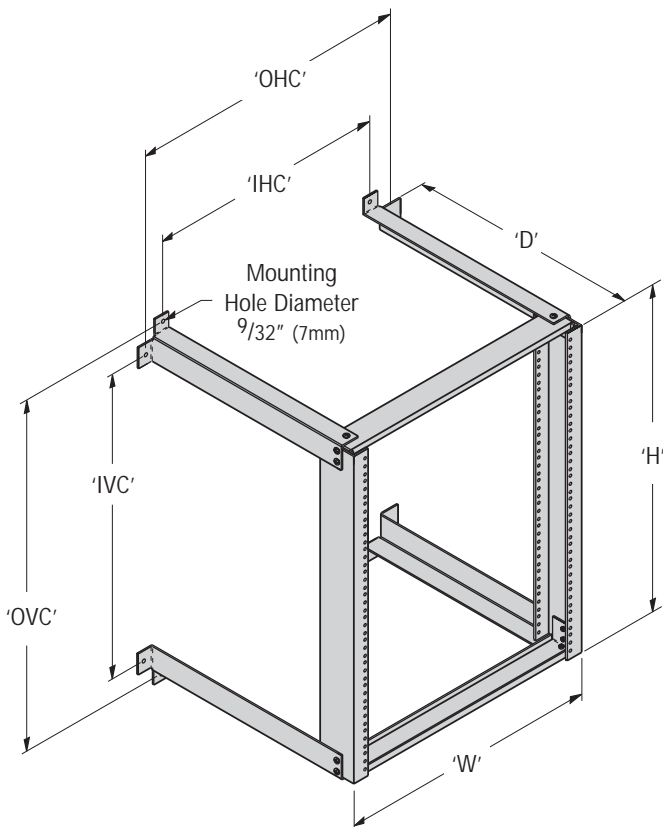

Mtg. U's	Mounting Hole Spacing							
	Horizontal Centers				Vertical Centers			
	Outside 'OHC'		Inside 'IHC'		Outside 'OVC'		Inside 'IVC'	
	in.	(mm)	in.	(mm)	in.	(mm)	in.	(mm)
For 20⁵/₁₆" (516mm) Rack Width								
14	21 ⁷ / ₈	555	18 ⁹ / ₁₆	471	27 ³ / ₁₆	690	23 ⁹ / ₁₆	598
22	21 ⁷ / ₈	555	18 ⁹ / ₁₆	471	41 ³ / ₁₆	1046	37 ⁹ / ₁₆	954
42	21 ⁷ / ₈	555	18 ⁹ / ₁₆	471	76 ³ / ₁₆	1935	72 ⁹ / ₁₆	1843
For 24⁵/₁₆" (617mm) Rack Width								
14	25 ⁷ / ₈	657	22 ⁹ / ₁₆	573	27 ³ / ₁₆	690	23 ⁹ / ₁₆	598
22	25 ⁷ / ₈	657	22 ⁹ / ₁₆	573	41 ³ / ₁₆	1046	37 ⁹ / ₁₆	954
42	25 ⁷ / ₈	657	22 ⁹ / ₁₆	573	76 ³ / ₁₆	1935	72 ⁹ / ₁₆	1843

Wall Mount Relay Rack

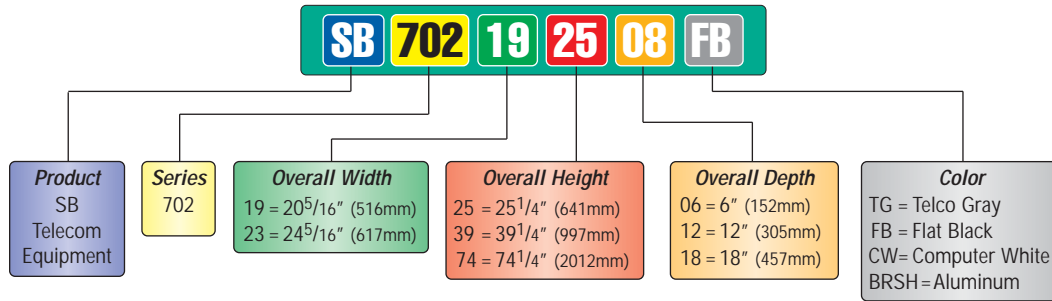

Part Number*	'W' Rack Width		'H' Height		Usable EIA Mounting U's	'D' Depth		Weight	
	in.	(mm)	in.	(mm)		in.	(mm)	lbs.	(kg)
SB702192506	20 ⁵ / ₁₆ "	516	25 ¹ / ₄ "	641	14	6"	152	6.8	3.1
SB702192512	20 ⁵ / ₁₆ "	516	25 ¹ / ₄ "	641	14	12"	305	7.7	3.5
SB702192518	20 ⁵ / ₁₆ "	516	25 ¹ / ₄ "	641	14	18"	457	8.7	3.9
SB702193906	20 ⁵ / ₁₆ "	516	39 ¹ / ₄ "	997	22	6"	152	9.0	4.1
SB702193912	20 ⁵ / ₁₆ "	516	39 ¹ / ₄ "	997	22	12"	305	9.9	4.5
SB702193918	20 ⁵ / ₁₆ "	516	39 ¹ / ₄ "	997	22	18"	457	10.8	4.9
SB702197406	20 ⁵ / ₁₆ "	516	74 ¹ / ₄ "	2012	42	6"	152	14.4	6.5
SB702197412	20 ⁵ / ₁₆ "	516	74 ¹ / ₄ "	2012	42	12"	305	15.3	6.9
SB702197418	20 ⁵ / ₁₆ "	516	74 ¹ / ₄ "	2012	42	18"	457	16.3	7.4
SB702232506	24 ⁵ / ₁₆ "	617	25 ¹ / ₄ "	641	14	6"	152	7.0	3.2
SB702232512	24 ⁵ / ₁₆ "	617	25 ¹ / ₄ "	641	14	12"	305	8.0	3.6
SB702232518	24 ⁵ / ₁₆ "	617	25 ¹ / ₄ "	641	14	18"	457	8.9	4.0
SB702233906	24 ⁵ / ₁₆ "	617	39 ¹ / ₄ "	997	22	6"	152	9.2	4.2
SB702233912	24 ⁵ / ₁₆ "	617	39 ¹ / ₄ "	997	22	12"	305	10.1	4.6
SB702233918	24 ⁵ / ₁₆ "	617	39 ¹ / ₄ "	997	22	18"	457	11.1	5.0
SB702237406	24 ⁵ / ₁₆ "	617	74 ¹ / ₄ "	2012	42	6"	152	14.6	6.6
SB702237412	24 ⁵ / ₁₆ "	617	74 ¹ / ₄ "	2012	42	12"	305	15.6	7.1
SB702237418	24 ⁵ / ₁₆ "	617	74 ¹ / ₄ "	2012	42	18"	457	16.5	7.5

* Add Color Code suffix to complete part number.

Heavy Duty Wall Mount Relay Rack

The Heavy Duty Wall Mount Relay Rack provides a economical solution for loads up to 200 lb. static load capacity. This rack is used when equipment and patch panel installations do not require security.

Features

- Extra deep fixed wall rack provides mounting depth up to 30" (762mm)
- Rated for 200 lb. (91kg) load capacity (dependent on wall strength and anchors)
- Double sided universal ($\frac{5}{8}$ " (16mm), $\frac{5}{8}$ " (16mm), $\frac{1}{2}$ " (13mm)) mounting hole spacing
- #12-24 panel mounting holes
- Conformance to EIA-310-D
- 19" (482mm) & 23" (584mm) widths
- 14U = 25" (635mm), 22U = 39" (990mm) and 42U = 72" (1829mm) heights
- 18" (457mm), 24" (609mm) and 30" (762mm) depths
- Material: 6061-T6 aluminum alloy
- Finish: Brushed Aluminum (BRSH)
Telco Gray Powder Coat (TG)
Flat Black Powder Coat (FB) or
Computer White Powder Coat (CW)

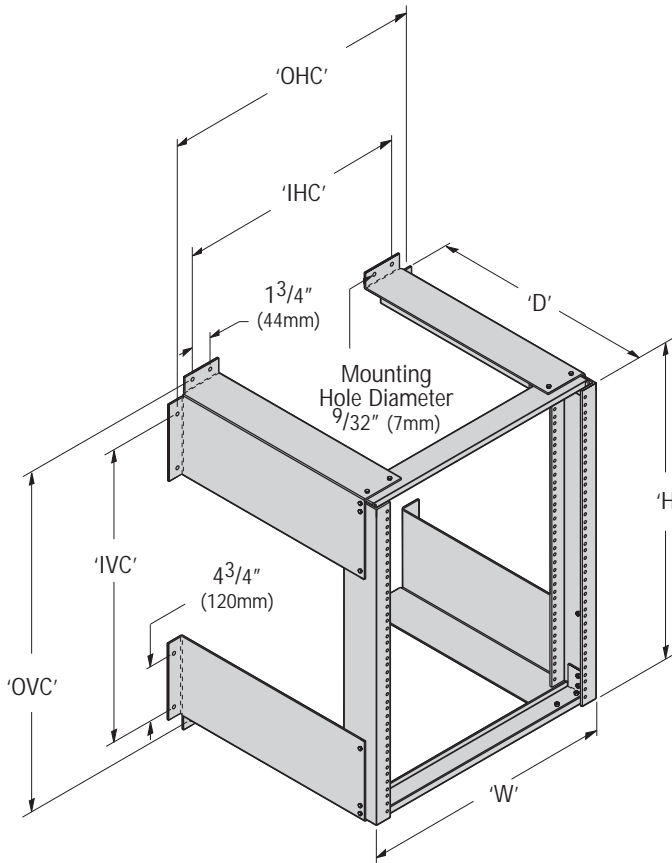

Mtg. U's	Mounting Hole Spacing							
	Horizontal Centers				Vertical Centers			
	Outside 'OHC'		Inside 'IHC'		Outside 'OVC'		Inside 'IVC'	
	in.	(mm)	in.	(mm)	in.	(mm)	in.	(mm)
For 20⁵/₁₆" (516mm) Rack Width								
14	21 ⁹ / ₁₆	548	19 ³ / ₁₆	487	27 ¹ / ₁₆	687	23 ¹¹ / ₁₆	601
22	21 ⁹ / ₁₆	548	19 ³ / ₁₆	487	41 ¹ / ₁₆	1043	37 ¹¹ / ₁₆	957
42	21 ⁹ / ₁₆	548	19 ³ / ₁₆	487	76 ¹ / ₁₆	1932	72 ¹¹ / ₁₆	1846
For 24⁵/₁₆" (617mm) Rack Width								
14	25 ⁹ / ₁₆	649	23 ³ / ₁₆	598	27 ¹ / ₁₆	687	23 ¹¹ / ₁₆	601
22	25 ⁹ / ₁₆	649	23 ³ / ₁₆	598	41 ¹ / ₁₆	1043	37 ¹¹ / ₁₆	957
42	25 ⁹ / ₁₆	649	23 ³ / ₁₆	598	76 ¹ / ₁₆	1932	72 ¹¹ / ₁₆	1846

Heavy Duty Wall Mount Relay Rack

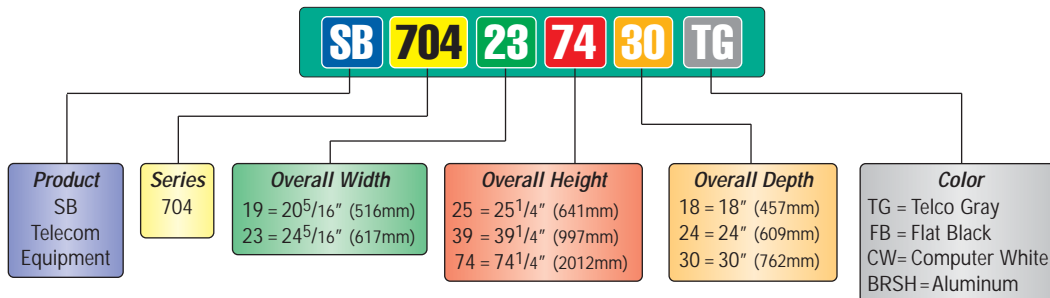

Part Number*	'W' Rack Width		'H' Height		Usable EIA Mounting U's	'D' Depth		Weight	
	in.	(mm)	in.	(mm)		in.	(mm)	lbs.	(kg)
SB704192518	20 ⁵ / ₁₆ "	516	25 ¹ / ₄ "	641	14	18"	457	10.2	4.6
SB704192524	20 ⁵ / ₁₆ "	516	25 ¹ / ₄ "	641	14	24"	609	11.5	5.2
SB704192530	20 ⁵ / ₁₆ "	516	25 ¹ / ₄ "	641	14	30"	762	13.1	5.9
SB704193918	20 ⁵ / ₁₆ "	516	39 ¹ / ₄ "	977	22	18"	457	13.5	6.1
SB704193924	20 ⁵ / ₁₆ "	516	39 ¹ / ₄ "	977	22	24"	609	14.9	6.7
SB704193930	20 ⁵ / ₁₆ "	516	39 ¹ / ₄ "	977	22	30"	762	16.2	7.3
SB704197418	20 ⁵ / ₁₆ "	516	74 ¹ / ₄ "	2012	42	18"	457	21.6	9.8
SB704197424	20 ⁵ / ₁₆ "	516	74 ¹ / ₄ "	2012	42	24"	609	22.9	10.4
SB704197430	20 ⁵ / ₁₆ "	516	74 ¹ / ₄ "	2012	42	30"	762	24.5	11.1
SB704232518	24 ⁵ / ₁₆ "	617	25 ¹ / ₄ "	641	14	18"	457	12.7	5.7
SB704232524	24 ⁵ / ₁₆ "	617	25 ¹ / ₄ "	641	14	24"	609	14.0	6.3
SB704232530	24 ⁵ / ₁₆ "	617	25 ¹ / ₄ "	641	14	30"	762	15.6	7.1
SB704233918	24 ⁵ / ₁₆ "	617	39 ¹ / ₄ "	997	22	18"	457	16.0	7.2
SB704233924	24 ⁵ / ₁₆ "	617	39 ¹ / ₄ "	997	22	24"	609	17.4	7.9
SB704233930	24 ⁵ / ₁₆ "	617	39 ¹ / ₄ "	997	22	30"	762	18.7	8.5
SB704237418	24 ⁵ / ₁₆ "	617	74 ¹ / ₄ "	2012	42	18"	457	24.1	10.9
SB704237424	24 ⁵ / ₁₆ "	617	74 ¹ / ₄ "	2012	42	24"	609	25.4	11.5
SB704237430	24 ⁵ / ₁₆ "	617	74 ¹ / ₄ "	2012	42	30"	762	27.0	12.2

* Add Color Code suffix to complete part number.



Keyboard Shelves

These sliding and tilting shelves are designed to accommodate "19 keyboards". The shelf installs in 2U and has a load capacity of 20 lbs. (9.1kg).

Part Number See Color Code Below To Complete Part Number	EIA Mounting Width in.	'L'		Shipping Weight	
		in.	(mm)	lbs.	(kg)
E2SHKBS19 _	19	16 ³ / ₈	416	10.0	4.5
E2SHKBS23 _	23	20 ³ / ₈	517	11.0	5.0



Keyboard Shelf with Mouse Tray

These sliding and tilting shelves are designed to accommodate "19 keyboards" and features an articulating mouse tray. The shelf installs in 2U and has a load capacity of 20 lbs. (9.1kg).

Part Number See Color Code Below To Complete Part Number	EIA Mounting Width in.	'L'		Shipping Weight	
		in.	(mm)	lbs.	(kg)
E2SHKBSLPM19 _	19	16 ³ / ₈	416	11.2	5.1
E2SHKBSLPM23 _	23	20 ³ / ₈	517	12.2	5.6

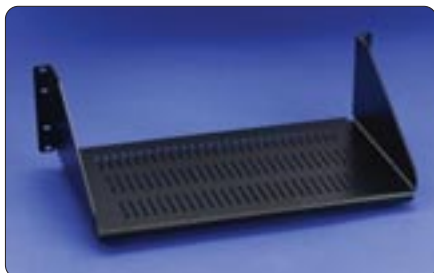

Single Sided - Ventilated Shelves

These ventilated shelves are designed to support monitors, CPUs, modems or other equipment requiring ventilation. The shelf installs in 3U and has a load capacity of 100 lbs. (45.3kg).

Part Number	Rack Width		Shelf Width 'A'		Depth 'B'		Mounting Hole Width 'C'		Weight	
	in.	(mm)	in.	(mm)	in.	(mm)	in.	(mm)	lbs.	(kg)
SB747V1910 _	19"	482	17 ¹ / ₂ "	444	10"	254	18 ⁵ / ₁₆ "	465	2.3	1.0
SB747V1915 _	19"	482	17 ¹ / ₂ "	444	15"	381	18 ⁵ / ₁₆ "	465	3.2	1.4
SB747V2310 _	23"	584	21 ¹ / ₂ "	546	10"	254	22 ⁵ / ₁₆ "	567	2.5	1.1
SB747V2315 _	23"	584	21 ¹ / ₂ "	546	15"	381	22 ⁵ / ₁₆ "	567	3.1	1.4

— Color Code
 A = Light Gray
 B = Black
 BG = Beige



Patch Cord Organizers

Organize and provide strain relief for your horizontal and vertical cable runs. Patch Cord Organizer panel and cable rings are powder coated steel with Polyethylene wire saddles. All mounting hardware is included.

Part Number See Color Code At Bottom to Complete Part Number	EIA Mtg. Width in.	Number of Wire Saddles	Mtg. Spaces 'U'	Shipping Weight	
				lbs.	(kg)
SB719191	19	24	1	2.3	1.04
SB719192L	19	24	2	2.8	1.27
SB719231	23	24	1	2.8	1.27
SB719232L	23	24	2	3.4	1.54

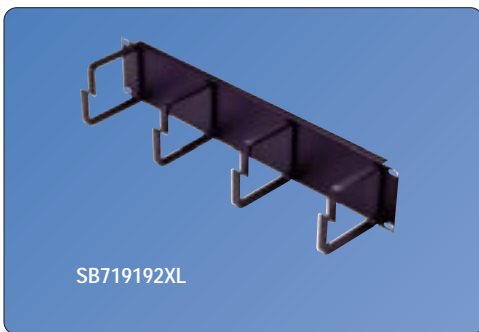

Horizontal Cable Organizers

Organizes horizontal cable runs. Cable Organizers are powder coated steel. All mounting hardware is included.

Part Number See Color Code At Bottom to Complete Part Number	EIA Mtg. Width in.	Inside Depth		Inside Height		Mtg. Spaces 'U'	Shipping Weight	
		in.	(mm)	in.	(mm)		lbs.	(kg)
SB719192XL	19	3 1/2	89	3	76	2	1.0	0.45
SB719194XL	19	3 1/2	89	6 1/2	165	4	2.0	0.90
SB719232XL	23	3 1/2	89	3	76	2	1.2	0.54
SB719234XL	23	3 1/2	89	6 1/2	165	4	2.4	1.09

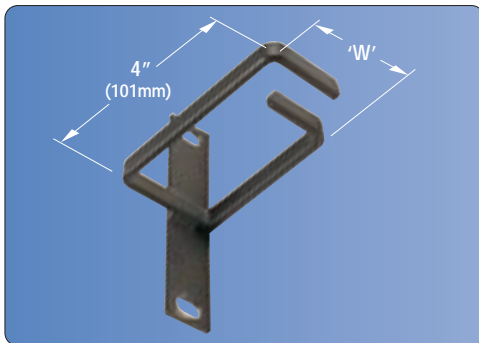

Cable Guide

Cable Guides are designed to install directly on mounting rails for vertical cable management. Guides are powder coated steel.

Part Number See Color Code At Bottom to Complete Part Number	Width 'W'		Mounting Spaces 'U'	Weight	
	in.	(mm)		lbs.	(kg)
SB563222	2	51	2	0.8	0.3
SB563242	4	101	2	2.4	1.1

Note: Sold in standard packages of two (2).



Plastic Cable Hoops

New innovation to the D-Ring. This flexible cable hoop provides easy cable bundle management. Material is SR5 Polypropylene gray.

Part Number	Opening		Shipping Weight	
	in.	(mm)	lbs.	(kg)
CTL	4 1/8 x 1 3/4	105 x 45	1.0	0.4
CTS	2 3/4 x 1 3/16	70 x 30	1.0	0.4

— Color Code
A = Light Gray
B = Black



Cable wrap

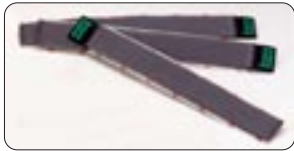
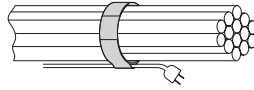

Cable catch

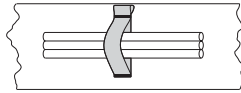

Cable strap

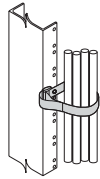

Cable hanger

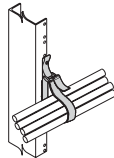

Velcro® Cable Accessories

Part Number	Length		Shipping Weight	
	in.	(mm)	lbs.	(kg)
Cable Wrap (Yellow Nylon)				
SB72558x5	5/8 x 5	16 x 127	0.1	0.04
SB7251x10	1 x 10	25 x 254	0.1	0.04
Cable Catch (Gray Nylon)				
SB72658x4	5/8 x 4	16 x 101	0.1	0.04
SB7261x8	1 x 8	25 x 203	0.1	0.04
Cable Strap (Gray Nylon)				
SB72758x6	5/8 x 6	16 x 152	0.1	0.04
Cable Hanger (Gray Nylon)				
SB72834x6	3/4 x 6	19 x 152	0.1	0.04

Note: Sold in standard packages of ten (10).



Screws



Cage Nuts

Screws & Cage Nuts

Part Number	Description	Finish	Shipping Weight	
			lbs.	(kg)
Screws				
E2MA1032PHMS100	#10-32 Phillips	Clear Zinc	0.1	0.04
E2MA1224PHMS100	#12-24 Phillips	Clear Zinc	0.1	0.04
Cage Nuts				
E2MACN1032100	#10-32 Tapped	Clear Zinc	0.1	0.04
E2MACN1224100	#12-24 Tapped	Clear Zinc	0.1	0.04

Note: Sold in standard packages of one hundred (100).



Horizontal Rack Mount Power Strips

- 19" EIA rack mounted power strips are available with or without surge protection. Both with 15 amp circuit breaker, six (6) outlet configuration and 6 ft. (1.8m) long grounded cord. Strip installs in 1U.
- Surge unit - 640 joules
- Color: Black

Part Number	Description	Shipping Weight	
		lbs.	(kg)
E2PSRM6P15ASS	With Surge Protection	0.1	0.04
E2PSRM6P15ANS	Without Surge Protection	0.1	0.04



Grounding Bars

Part Number	Rating	Size		Shipping Weight	
		'W' x 'H' x 'L' in.	'W' x 'H' x 'L' (mm)	lbs.	(kg)
E2-MA-GB	100 Amp@65°C	1/8 x 3/4 x 6	3 x 19 x 162	1.0	0.4

Ask about... other B-Line Data and Telecommunications Products



- Cooper B-Line Telecom Equipment Supports
- Cooper B-Line Cabinet Systems

For more information visit www.cooperbline.com

- Telco Racks • Premise Racks • Server Enclosures •
- Wall Mount Cabinets • Spring Steel Fasteners •
- Cable Tray • Wire Basket • Cent-R-Rail •





Electrical Enclosures



Cable Runway & Relay Racks

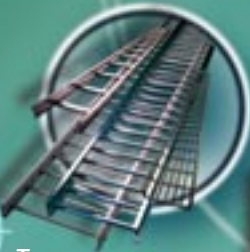

Cable Tray



Spring Steel Fasteners



Bolted Framing



Pipe Hangers

Cooper B-Line
509 West Monroe Street
Highland, IL 62249

Phone: 1-800-851-7415
Fax: 618-654-1917

www.cooperbline.com

Questions, Comments, Suggestions?

"B-VOCALSM
with B-Line"

Voice Of the Customer...Actively Listening
bvocal@cooperbline.com
618-654-2184 ext. 456

B-Line
SYSTEMS THAT MAKE SENSE

