

---

### Technical Data

#### ➤ **Product Description**

Nelson Firestop Putty (FSP™) is a completely pre-mixed and ready-to-use firestop product that can be hand pressed into place forming an immediate fire seal. When exposed to fire the putty material forms a hard char that creates a formidable barrier to smoke and flame. FSP™ is a blend of organic and inorganic materials that is hand moldable. FSP™ is reusable when adding or changing penetrating items since the material remains pliable and does not set up.

#### ➤ **Application**

Nelson FSP™ requires no special skills or tools to install. To ensure adequate adhesion, all surfaces should be clean and free of dust, grease, oil, loose materials, rust or other substances. Apply the required depth of FSP™ over various backing materials as required. Ensure that the FSP™ makes complete contact with the inside surface of the opening and also the surface of each penetrating item. FSP™ is ideal for cable penetrations where cable additions are common due to the characteristic of FSP™ remaining pliable. It can also be used for metallic, non-metallic and insulated pipes, cable tray and ductwork applications in a variety of fire rated floor or wall constructions. Actual installation may vary according to the type of firestop application. Refer to available firestop systems.

#### ➤ **Availability**

**Bar** AA445 – 1" x 3" x 12" (36.0 cu. in.) – 10/Ctn.

**Bulk** AA0439 – 20 Lbs. (432 cu. in.)

**Pads** AA458 – 1/8" x 6" x 7" – 20/Ctn.

AA452 – 1/4" x 6" x 7" – 20/Ctn.

AA447 – 1/4" x 4" x 8" – 20/Ctn.

#### ➤ **Approvals**

Underwriters Laboratories Inc. "Fill, Void or Cavity Material (XHHW)", FM, ABS and USCG.

California State Fire Marshal.

City of New York, New York, Department of Buildings

- MEA 135-00-M
- MEA 196-84-M Vol. 3

#### ➤ **Features**

- Up to a 3-Hour Rating
- Reusable for Convenient Retrofit
- Smoke and Gas Tight
- Weather Resistant
- Excellent Shelf Life
- Acoustically Tested – Reduces noise transmission
- Halogen Free

#### ➤ **Physical Properties**

- Color.....Tan
- Density.....0.049 lbs/cu. in.
- Consistency.....7.00mm (Penetrometer)
- Application Temp...40°F (4°C) to 110°F (43°C)
- Dielectric strength...>356v/mil.
- STC Rating.....54

#### ➤ **Test Compliance**

- ASTM E84 Flame spread.....5  
Smoke developed.....10
- ASTM E90 Standard Test Method for Laboratory Measurement of Airborne Sound Transmission Loss of Building Partitions and Elements
- ASTM E814 and UL1479 - Test method for through stop fire penetrations.
- ANSI/UL 263, "Fire Tests of Building Construction and Materials."
- NFPA 70 "Wall Opening Protective Materials"

#### ➤ **Testing Data**

For specific test criteria, refer to the UL Fire Resistance Directory.

#### ➤ **Storage & Handling**

Nelson FSP™ should be stored indoors. Long term storage temperature: 140°F (60°C) maximum. There is no indication of shelf-life limitations. Partially used bars should be re-wrapped in their original packaging before being stored.

#### ➤ **Related References**

Underwriters Laboratories Inc. "Fire Resistance Directory". Application details are available in AutoCAD® format on request.

### ➤ INSTALLATION INSTRUCTIONS

**GENERAL:** Areas to be protected must be clean and free of oil, loose dirt or rust. Installation temperatures must be between 40°F (4°C) and 110°F (43°C).

**APPLICATION SYSTEM SELECTION:** Selection of an appropriate firestop application system design is critical to the fire protection process. Please consult the Nelson Firestop directory and application guide as well as the UL® Fire Resistance Directory for additional information.

**FORMING:** Some installations may require forming as either an integral part of the system or as an option to facilitate installation. In systems where forming is required, mineral wool batt with a minimum nominal density of 4PCF is generally required. Cut forming material oversized to allow for tight packing or use bulk fiber. Recess forming material to allow for proper depth of Putty.

**FILL MATERIAL:** Nelson Firestop FSP™ putty is suggested to be installed by hand. The putty should be installed no thinner than 3/4". FSP™ is normally installed from one side on floor penetrations and from both sides of a wall penetration. The putty should be packed from the bottom of the opening, starting at the back and working forward. FSP™ should be pushed into all voids. A minimum of 1/2" of FSP™ should surround each penetrating item (annular space). When this is not possible (such as a cable tray), a crown shall be built up around the bundle of penetrating items, using a second layer of putty. The crown should have a 30° slope with the wall or floor surface. Wall openings should not have an unsupported space of putty greater than 4". Floor openings should not have unsupported spaces of putty greater than 1-1/2".

#### **PUTTY PADS:**

Installation of FSP™ putty pads is determined by construction of wall "F" rating and size of electrical box to be covered. Using gloves, remove pad from plastic film. Apply pad onto electrical box by forming over backside of electrical box to completely cover exposed surfaces. It is not necessary to cover the side of the box against the stud to which it is mounted. An additional 1/4" thickness of putty is to be formed around the connector securing the end of each electrical metallic tube or conduit to the box. Installation of putty pads will allow the horizontal separation between outlet

boxes, on opposite sides of the wall, to be less than 24" provided that the boxes are not installed back-to-back.

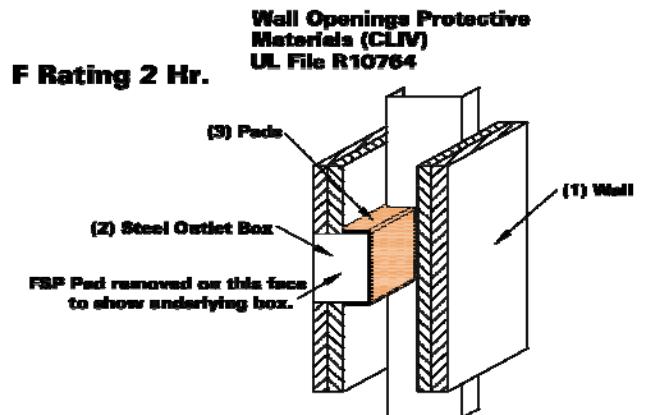

**WALL ASSEMBLY** - Constructed in the manner specified in the U400 series designs as shown in the UL Fire Resistance Directory.

**STEEL OUTLET BOX** - Max. 4" X 4" (102mm x 102mm) sized outlet box installed in accordance with NFPA 70 regulations. The box can be installed within the same stud cavity, provided they are not installed back-to-back.

**NELSON FSP PUTTY PADS** (part # AA452) - Min. 1/8" (3mm) thickness Putty pad. Putty pads are to be installed to completely cover the exterior surfaces of the outlet box (except for the side of the outlet box against the stud) and completely seal against the stud within the stud cavity. An additional 1/4" (6mm) thickness of putty is to be formed around the connector securing the end of each electrical metallic tube or conduit to the box. When moldable putty pad outlet box protective material is used on boxes on both sides of wall as directed, the horizontal separation between outlet boxes on opposite sides of the wall may be less than 24 in. (610mm) provided that the boxes are not installed back-to-back.

**DWG NO. FS-0210 R5**

### **UL System No. W-L-3190 F Rating 1 or 2 Hr. T Rating 0 Hr.**

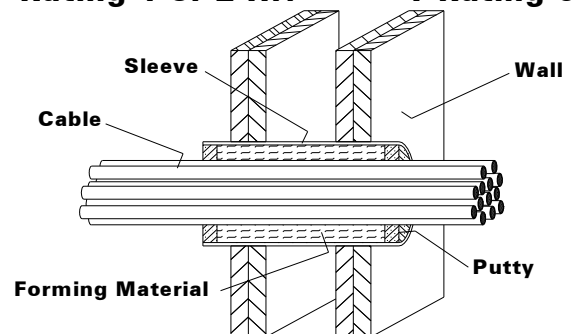

- **WALL ASSEMBLY** - Construct as specified in the U300 or U400 series designs. The max. diam. of the opening is 4". Annular space is 1/2" to 1".
- **METALLIC SLEEVE** - Max. nominal 4" diameter min. 28 GA steel sleeve having a min. 2" lap. Sleeve installed by coiling the sheet steel to a diameter smaller than the opening and releasing the coil to let it uncoil against the periphery of the opening. Sleeve will extend a nominal 2" beyond each surface of the wall.
- **CABLES** - Max. 40% fill of 100pr. #24awg., or smaller PVC jacketed telecommunications cables.
- **FORMING MATERIAL** - Tightly pack min. 4pcf mineral wool into the sleeve to the full depth.
- **NELSON FSP PUTTY** - Apply over the forming material to a min. 1-1/2" depth, flush with both ends of the sleeve.

**DWG NO. FS-0382 R0**

### **NELSON FIRESTOP PRODUCTS**

P.O. Box 726  
Tulsa, OK 74101

Toll Free: 800-331-7325  
www.nelsonfirestop.com

Direct: 918-627-5530  
e-mail: info@nelsonfirestop.com

Fax: 918-641-7336